

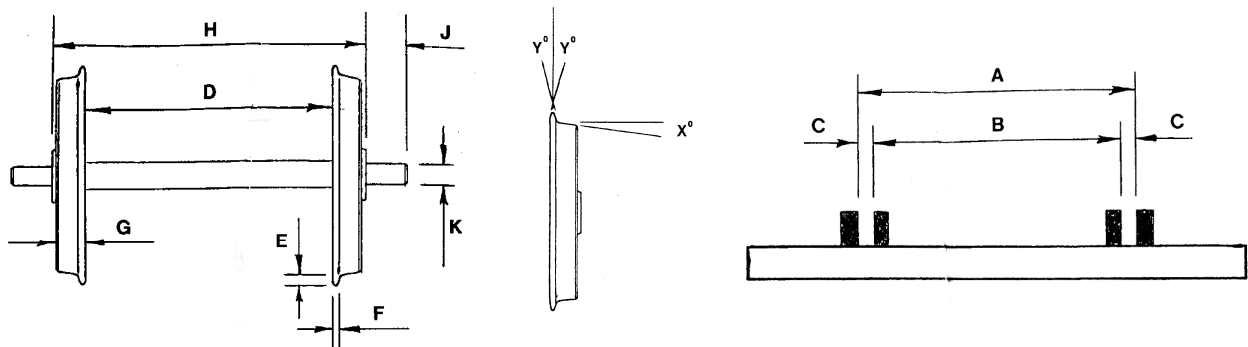

G3 Track Standard

S 01

The Gauge '3' track standards were developed by the founding Members of the Society, as guidance for Society Members to help them achieve safe & reliable running both on their own, and as importantly, on other members tracks. The standards were slightly revised in May 2010 but remain largely the same as the original 1990 version. Although the track standards are not mandatory, they are recommended.



		Metric mm	Imperial	Inches
A	Track Gauge	63.5	2.500	2 1/2"
B	Over Check Rails	56.5	2.218	2 7/32"
C	Flange way	3.5	0.140	9/64"
D	Wheel Back to Back	58.00	2.281	2 9/32"
E1	Flange Depth (Solid Axle Boxes)	2.3	0.094	3/32"
E2	Flange Depth (Sprung Axle Boxes)	2.0	0.080	5/64"
F	Flange Thickness	1.6	0.063	1/16"
G	Wheel Width (Minimum)	6.8	0.268	17/64"
H	Over Wheel Bosses	76.2	3.00	3"
J	Journal Length	8.0	0.313	5/16"
K	Journal Diameter	4.0	0.156	5/32"
X	Cone Angle		3 degrees	
Y	Flange Angle (Each Side)		10 degrees	

Buffers

Lateral distance between buffer centres	76.5 mm	3"
Buffer height above rails	46.4 mm	1.83"

Rolling Stock (Guidelines)

Maximum height above rail level	205 mm	8"
Overall width	140 mm	5 1/2"